

BoWex® HEW Compact Curved-tooth gear coupling®

Compensating for large displacements, very compact design

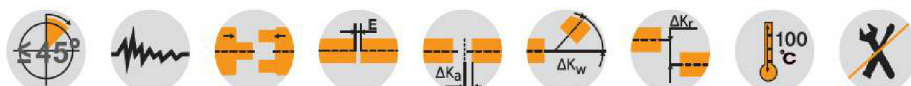

For legend of pictogram please refer to flapper on the cover



BoWex® type HEW Compact																		
Size	Max. finish bore d		Dimensions [mm]													Weight with pilot bored coupling [kg]	Mass moment of inertia with pilot bored coupling J ₁ [kgm ²]	Mass moment of inertia with pilot bored coupling J ₂ [kgm ²]
	d ₁	d ₂	D ₁	D ₂	D ₄	l ₁	l ₂	l ₃	l ₄	E	L	L ₁	D ₃	z	M			
42-130	42	42	90	65	131	42	42	45	37	34	118	98	78	6	M6	3,4	0,003	0,001
65-180	65	65	130	96	180	60	55	55	47	30	145	122	110	8	M10	9	0,014	0,006
80-225	75	80	145	124	225	70	90	77	51	50	210	158	120	10	M12	18,9	0,035	0,029
100-305	100	100	200	152	305	90	110	90	73	58	258	187	175	16	M12	40,2	0,152	0,087
125-365	125	125	235	192	365	120	140	150	90	68	328	240	205	12	M16	75	0,36	0,26

Technical data												
Coupling size	Elastomer hardness [Shore A]	Torque			Perm. operating speed n max. [1/min]	Perm. damping power			Dynamic torsion spring stiffness C _{tdyn} [Nm/rad]	Relative damping ψ	Resonance factor V _R ≈ 2·T/ψ	Radial spring stiffness C _r [N/mm]
		T _{KN} [Nm]	T _{Kmax} [Nm]	With 10 Hz T _{KW} [Nm]		P _{KW} [W]						
						60 °C	80 °C	90 °C				
BoWex 42 HEW Compact	T50	150	450	45	7300	24	12	6	780	0,6	10,5	178
	T65	180	540	54					2400	0,8	7,9	600
	T70	210	630	63					2900	1,2	5,2	710
BoWex 65 HEW Compact	T50	400	1200	120	5500	48	24	12	2850	0,6	10,5	379
	T65	500	1500	150					7800	0,8	7,9	955
	T70	575	1725	173					9500	1,2	5,2	1240
BoWex 80 HEW Compact	T50	900	2700	270	4400	96	48	24	5000	0,6	10,5	420
	T65	1100	3300	330					13000	0,8	7,9	1090
	T70	1300	3900	390					16500	1,2	5,2	1450
BoWex 100 HEW Compact	T50	2000	6000	600	3200	156	78	39	17000	0,6	10,5	760
	T65	2600	7800	780					44000	0,8	7,9	1850
	T70	3000	9000	900					50000	1,2	5,2	2250
BoWex 125 HEW Compact	T40	3000	9000	900	2900	192	96	48	15000	0,6	10,5	476
	T50	4000	12000	1200					25000	0,8	7,9	750
	T70	5000	15000	1500					62000	1,2	5,2	1930

Ordering example:	BoWex® 65 HEW Compact	T50	d ₁ Ø40	d ₂ Ø65
	Coupling size and type	Elastomer hardness	Finish bore H7 keyway to DIN 6885 sheet 1 (JS9)	Finish bore H7 keyway to DIN 6885 sheet 1 (JS9)

Components

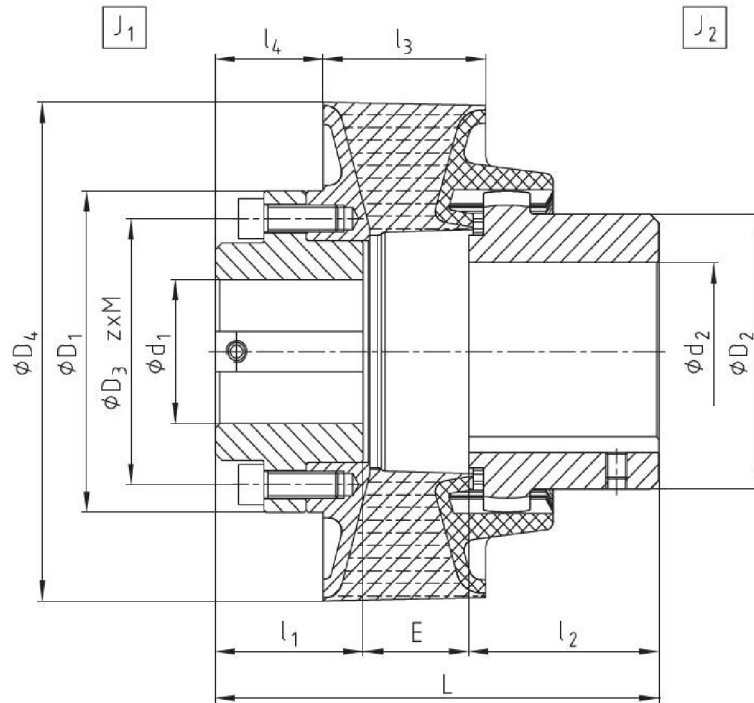

BoWex® HEW Compact with reduced hub

